



# ZEECO FREE JET Gen 3

## INDUSTRY-LEADING H<sub>2</sub> PROCESS BURNER TECHNOLOGY

4700 South Garnett Road | Tulsa, OK 74146 USA | +1 (918) 258 8551 | zeeco.com

### BREAKTHROUGH HYDROGEN BURNER TECHNOLOGY

Zeeco is known worldwide for driving burner innovation, and now we're introducing the ZEECO® FREE JET® Gen 3™, our latest burner breakthrough. This burner's unique design allows operators to fire 100% H<sub>2</sub> and various fuel blends while maintaining next-generation ultra-low NO<sub>x</sub> emissions – without sacrificing performance, flame shape, or safety.



100% NG



50% NG, 50% H<sub>2</sub>



100% H<sub>2</sub>

[CLICK HERE TO SEE IT FIRING](#)

### HOW IT WORKS

By reshaping the burner tile and using proven next generation ultra-low NO<sub>x</sub> burner technology, the FREE JET Gen 3 achieves unprecedented reductions in NO<sub>x</sub> emissions when firing up to 100% H<sub>2</sub>. Reimagining previous FREE JET designs, the FREE JET Gen 3 uses similar internal flue gas recirculation technology but with fewer staged fuel tips and a new fuel and air staging process. These changes, along with the square burner tile, create non-uniform areas of rich and lean fuel mixtures, allowing for precise control of primary tips to reduce thermal NO<sub>x</sub>.

### FREE JET GEN 3 BENEFITS:

- » Fire 100% H<sub>2</sub> and a variety of fuel blends
- » No complex controls required
- » Forced and natural draft options
- » No additional safety controls required
- » Fits almost any furnace
- » Designed for simple maintenance
- » No flashback
- » Turndown of heat release greater than 5:1
- » Near single-digit NO<sub>x</sub> emissions

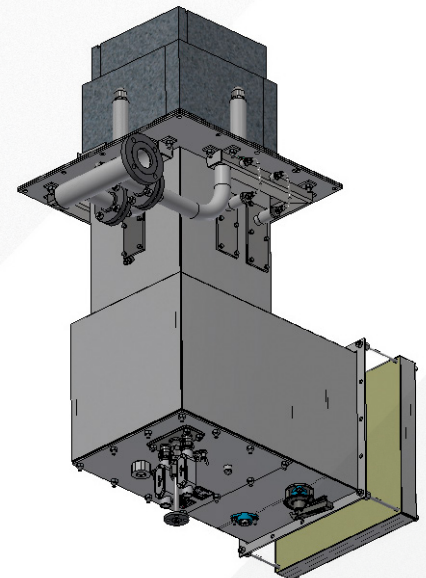



## RELY ON ZEECO'S ENGINEERED SOLUTIONS:

We know that you have questions about integrating H<sub>2</sub> into your furnaces. Zeeco is here to help you answer those questions and provide engineered solutions to help you fire H<sub>2</sub> today. Whether you want to fire 100% hydrogen, 100% hydrocarbons, or varying fuel blends, Zeeco can conduct a combustion survey to ensure you have the right equipment for the job. Rely on a team with proven H<sub>2</sub> firing experience.

### The Zeeco Difference



By concentrating on what we do best, Zeeco has grown into a worldwide leader in combustion and environmental solutions. We are a privately held company whose ownership stays highly involved in daily operations, with upper management comprised of the world's leading combustion experts. When you call Zeeco, we answer.

When you make a request, you get a quick, efficient response. We are lean and efficient, able to make decisions quickly, without bureaucracy and red tape. Our sales, engineering, and purchasing groups work hand-in-hand to deliver highly competitive quotes and heroic turnaround times. We stand ready and willing to travel anywhere in the world to discuss upcoming projects firsthand, and to ensure that every existing project runs seamlessly.

Zeeco Headquarters  
4700 South Garnett Road  
Tulsa, OK 74146

Learn more at [zeeco.com](https://zeeco.com)

✉ [sales@zeeco.com](mailto:sales@zeeco.com)

☎ +1 (918) 258 8551



REGISTERED  
ISO 9001:2015

Certification applies to  
Zeeco Headquarters.



Visit [zeeco.com/contact](https://zeeco.com/contact)  
for additional Global Location  
contact information

**GO**   
**ZEECO**®

Choose to work with our dedicated, flexible, and innovative team, and you won't be disappointed. Call or email us today to request a quote or to learn more about our proprietary combustion systems.