

PROFLAME+™ UTILITY GRADE FLAME SCANNER

Model ZPF-1200UV / ZPF-1200IR / Model ZPF-1200DS



BURNERS | FLARES | THERMAL OXIDIZERS | VAPOR CONTROL | RENTALS | AFTERMARKET



The ZEECO® ProFlame+™ integrated flame scanner revolutionizes the industry by providing reliable flame detection and superior background flame discrimination for safer operation. Easily configurable set points using intuitive PC-based software also allows for in-depth flame analysis.

Design Features and Benefits

- UV, IR, or dual sensor models available. Front mount or fiber optic available
- Compact, fully integrated and exceptionally reliable
- State-of-the-art digital signal processing for easy flame analysis
- Easily configurable frequency and gain settings for simple set-up
- Intuitive PC-based software to assist in troubleshooting
- Microprocessor-based with electronic self-check for SIL3 applications
- Durable housing for a variety of operating environments
- Independently adjustable Flame-On and Flame-Off response times: 1-6 sec.
- Reliable 0/4-to-20 mA flame intensity output

Operating Environment

- Temperature: -20°C (-4°F) to +70°C (158°F)
- Relative humidity: 0% to 95% non-condensing
- Environmental protection rating: IP 65, NEMA 4X
- Hazardous rating: II 3 G Ex nAnC IIC T6
- Weight: 3.3 Lbs (1.5 kg)
- Mounting: 1" NPT F
- Housing material: aluminum, painted finish
- Cable: quick disconnect, 8 conductor cable

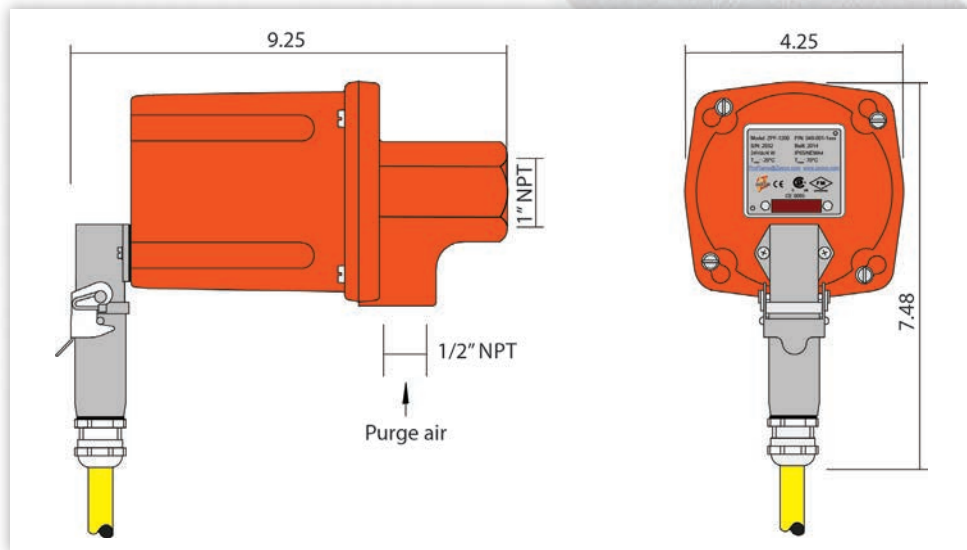

Operating Parameters - Input

Input voltage

Supply voltage: 24V dc \pm 10%-15%

Power consumption: 4 W

Purge air

Cool, dry, clean air: 5 scfm (142 l/min) at 5" wc (12.5 mbar) above windbox or furnace pressure (sight tube exit point), \leq 38°C (100°F) at wye fitting

Operating Parameters - Output

- Output relay: SPDT, Flame-On is the N.O. contact and Flame-Off is the N.C. contact. Fault output: 24Vdc
- Contact rating: 48V dc at 1.0 A
- Flame intensity output: 0/4 to 20 mA referenced to 24V dc common; 250Ω max load resistance
- Flame status indication: Yellow LED for local Flame-On indication and Green LED for intensity. Flame signal trending, flame relay, marginal relay, flicker frequency, flame amplitude and raw signal analysis via PC-based scanner software.



The Zeeco Difference

By concentrating on what we do best, Zeeco has grown into a worldwide leader in combustion and environmental solutions. We are a privately held company whose ownership stays highly involved in daily operations, with upper management comprised of the world's leading combustion experts.

When you call Zeeco, we answer. When you make a request, you get a quick, efficient response. We are lean and efficient, able to make decisions quickly, without bureaucracy and red tape. Our sales, engineering, and purchasing groups work hand-in-hand to deliver highly competitive quotes and heroic turnaround times. We stand ready and willing to travel anywhere in the world to discuss upcoming projects firsthand, and to ensure that every existing project runs seamlessly.

Zeeco Headquarters
22151 East 91st Street
Broken Arrow, OK 74014

Learn more at zeeco.com

✉ sales@zeeco.com

☎ +1 (918) 258 8551



REGISTERED
ISO 9001: 2015

Certification applies to
Zeeco Headquarters.



Visit zeeco.com/contact
for additional Global Location
contact information

GO
ZEECO

Choose to work with our dedicated, flexible, and innovative team, and you won't be disappointed. Call or email us today to request a quote or to learn more about our proprietary combustion systems.